



Waterproofing Pipe Penetrations

SCOPE

Application Instruction 303 addresses the situation where a pipe is passing through a concrete slab or wall in either new construction or existing structures. Use this procedure to stop or prevent leakage as a result of water traveling along the interface of the concrete and the pipe.

SAFETY PRECAUTIONS

Cementitious compounds become caustic when mixed with water or perspiration and can cause serious chemical burns. Avoid contact with skin or eyes. Avoid breathing dust. Wear safety goggles, impervious gloves and long sleeves. See the Material Safety Data Sheet for more information.

STEP 1: PREPARE A RECESSED CHASE

If repairing an existing structure, begin by chiseling around the pipe to the dimensions of 40 mm (1.5 inches) deep by 25 mm (1-inch) wide as described in Application Instruction 301. If the penetration will be in new construction, chiseling can be avoided by forming the chase when the concrete is placed using a flexible form made from foam or other suitable material.

STEP 2: STOP ANY FLOWING OR SEEPING WATER (if applicable)

Note: If the interface of the concrete and the pipe is dry at the time of the repair, you may skip step 2 and go on to step 3.

TIP: Be sure that your chase is at least 40mm (1.5") deep or you will not have enough room to complete your repair.

Mix plug to a putty consistency and press the putty into the chase stopping the water in that spot. This step is described in Application Instruction 301 in more detail.

STEP 3: PREPARATION

Before installing the repair materials, it is necessary to prepare the pipe surface so that the repair products will adequately adhere to the pipe.

Metal Pipes: The surface of a metal pipe must be prepared by cleaning and roughening the area that will be in contact with the Krystol® repair materials. Remove all grease, oil, corrosion, and scale. Abrade by coarse sanding or sandblasting to achieve a coarse surface profile.

PVC or ABS Pipes: The surface of a PVC or ABS pipe must be prepared by applying a silica sand layer to the area that will be in contact with the Krystol® repair materials. The sand is adhered to the pipe using the joint cement (glue) that is normally used to assemble the pipe sections.

Using the appropriate joint cement for the material (either PVC or ABS joint cement), apply a heavy coating of joint cement to the pipe in the area that will be in contact with the Krystol repair materials. Immediately apply dry silica sand to the joint cement to completely cover it. Allow the joint cement to harden then remove excess loose sand using a blow pipe or vacuum. This will result in a continuous coating of dry silica sand firmly cemented around the pipe. This dry sand layer will provide for adhesion of the Krystol repair materials.

Soak Concrete Thoroughly: Ensure that the concrete is saturated with water before the application of Krystol T1® and Bari-Cote. A saturated-surface-dry (SSD) condition is extremely important to your success. The concrete must be completely saturated with water to allow the

TOOLS AND MATERIALS

- Krystol Waterstop Grout™ or
- Krystol T1® and Krystol Bari-Cote™
- Krystol Plug™
- Clean water source
- Mixing bucket and mixer
- Chipping hammer with 25 mm (1-inch) square blade chisel
- One inch wide margin trowel

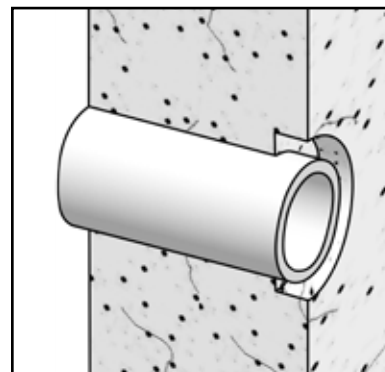

Step 1
Prepare a recessed chase

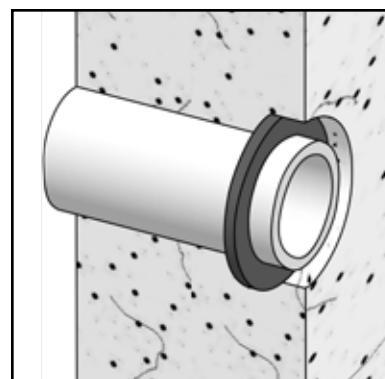

Step 2
Stop any flowing or seeping water using plug if applicable



Application Instructions

Application Instruction 303

Krystol chemicals to penetrate deeply and react. The outer surface, however, must be only slightly damp, so as not to dilute and weaken the bond of the Krystol application.

NEW CONSTRUCTION STEP 4: INSTALL KRYSTOL WATERSTOP GROUT

Mix Krystol Waterstop Grout to a putty consistency. Fill the chase with Krystol Waterstop Grout so that it is flush with the surface.

LEAK REPAIR STEPS 4&5: INSTALL KRYSTOL T1 & BARI-COTE

Complete the installation following Application Instruction 301. Install Krystol T1 to a thickness of 1/2 inch then fill the rest of the chase with Bari-Cote flush to the surface (outer third or outer two-thirds if step 2 was skipped).

This repair is simply a modification of the application method described in Application Instruction 301. You will need to refer to that document to complete this application properly.

CURING

Krystol products develop significant heat during the hardening process and are prone to rapid drying. Protect the application from rapid drying for at least 48 hours by repeatedly misting with water or other acceptable curing method. Protect against freezing temperatures for at least 24 hours.

New Construction

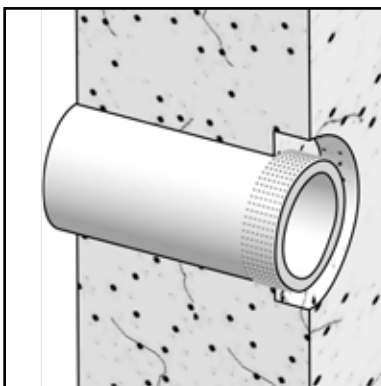

Step 3
Prepare pipe surface

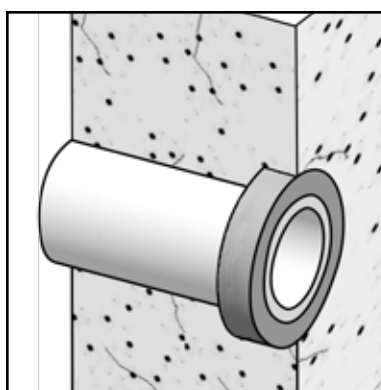

Step 4
Install Krystol Waterstop Grout

Leak Repair

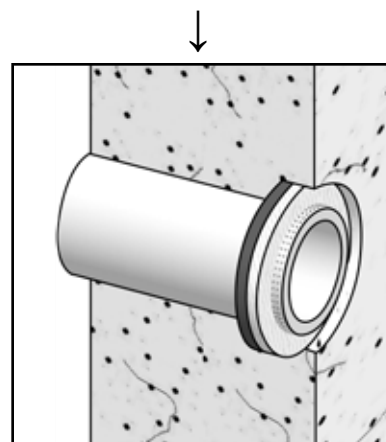
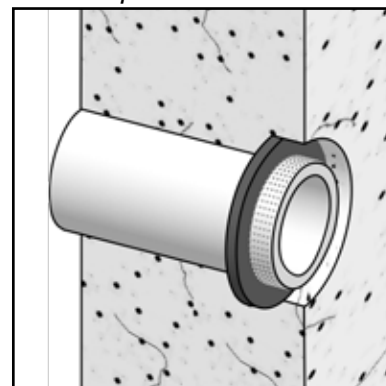

Step 4
Install Krystol T1®

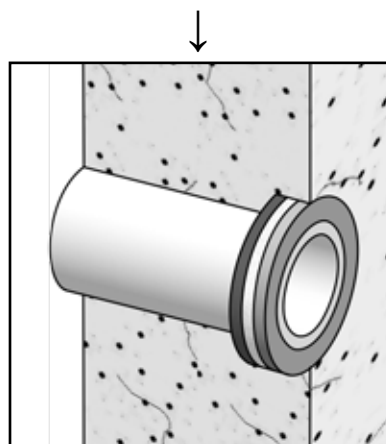

Step 5
Install Krystol Bari-Cote